

# Liquidline Q1 Evo

## Bean to Cup Machine

The Liquidline Q1 Evo is a compact bean-to-cup coffee machine designed for reliable performance in small to medium commercial settings. Capable of producing up to 60 drinks a day, it features fresh bean grinding, an intuitive touchscreen and dual powder hoppers for milk and chocolate. Its space-saving design and flexible installation make it ideal for offices, retail spaces and customer-facing environments.



# Liquidline

## Q1 Evo

---

Built for ease of use and reliable daily output, the Q1 Evo delivers a wide selection of drinks through an intuitive, fully automated system. Its compact footprint houses high-capacity ingredient canisters and a precision brewing unit, supporting consistent results throughout the day while keeping user input to a minimum.

### **PRECISION GRINDING & BREWING**

The Q1 Evo uses a flat burr grinder with micrometric adjustment to ensure consistent grind size and accurate extraction. Combined with an automated brewing system, this delivers reliable in-cup quality across every drink, helping maintain flavour and consistency without manual calibration.

### **INTUITIVE TOUCHSCREEN INTERFACE**

With dedicated canisters for milk powder and chocolate, the Q1 Evo offers a broad selection of beverages, from espresso and americanos to cappuccinos, mochas and hot chocolate. This allows businesses to offer variety without the need for fresh milk handling or additional equipment.

### **VERSATILE DRINKS MENU**

A responsive touchscreen with up to 8 drink selections simplifies operation for all users. Clear drink icons and straightforward navigation reduce training requirements and support quick, efficient service in self-serve and shared environments.

### **COMPACT, FLEXIBLE DESIGN**

With a narrow footprint and integrated water tank, the Q1 Evo can be easily positioned in a wide range of locations. Its compact design makes it well-suited to areas with limited space, while still delivering the performance expected from a commercial coffee solution.



“

The Q1 Evo delivers reliable bean to cup performance with a modern and easy to use touchscreen interface!”

# Technical Information

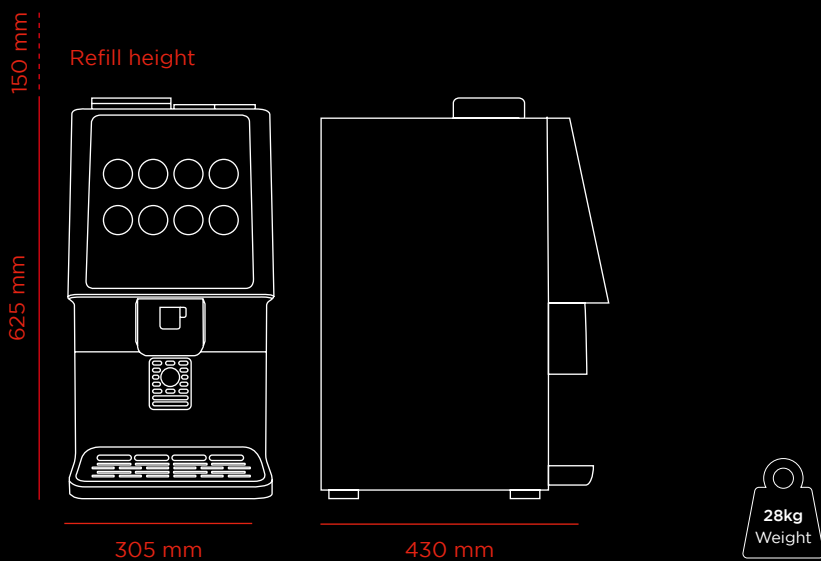

## Specification

Product ID	CTQIE
Cups per Day	Up to 60 Cups
Standard Drinks Configurations	Espresso, Americano, Flat White, Caffe Latte, Cappuccino, Hot Chocolate, Mocha, Hot Water
Bean Hopper Capacity	1 x 1.2 kg
Powder Hopper Capacity	2 x 1.6 L
Milk	Powdered Milk
Energy	220-240V
Water	Manual Fill or Plumbed In
Dimensions	430(D) x 305(W) x 625(H) mm

## Have You Thought About?



Liquidline Ice Dispenser  
ICEDISAPI

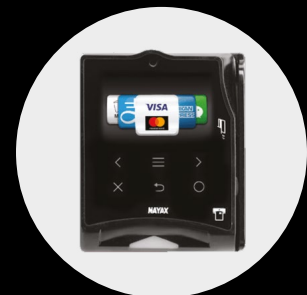

Nayax Contactless  
Payment System  
NAYAXCR-TB

## Get in Touch

liquidline.co.uk  
sales@liquidline.co.uk  
0800 849 9110

liquidline.ie  
sales@liquidline.ie  
01 963 0314